

# PARTS DIAGRAM

for use with "P" serial numbers 2-year warranty

## EDGE 50

50 LBS THRUST - 12 VOLT - 42" SHAFT  
42 AMPS

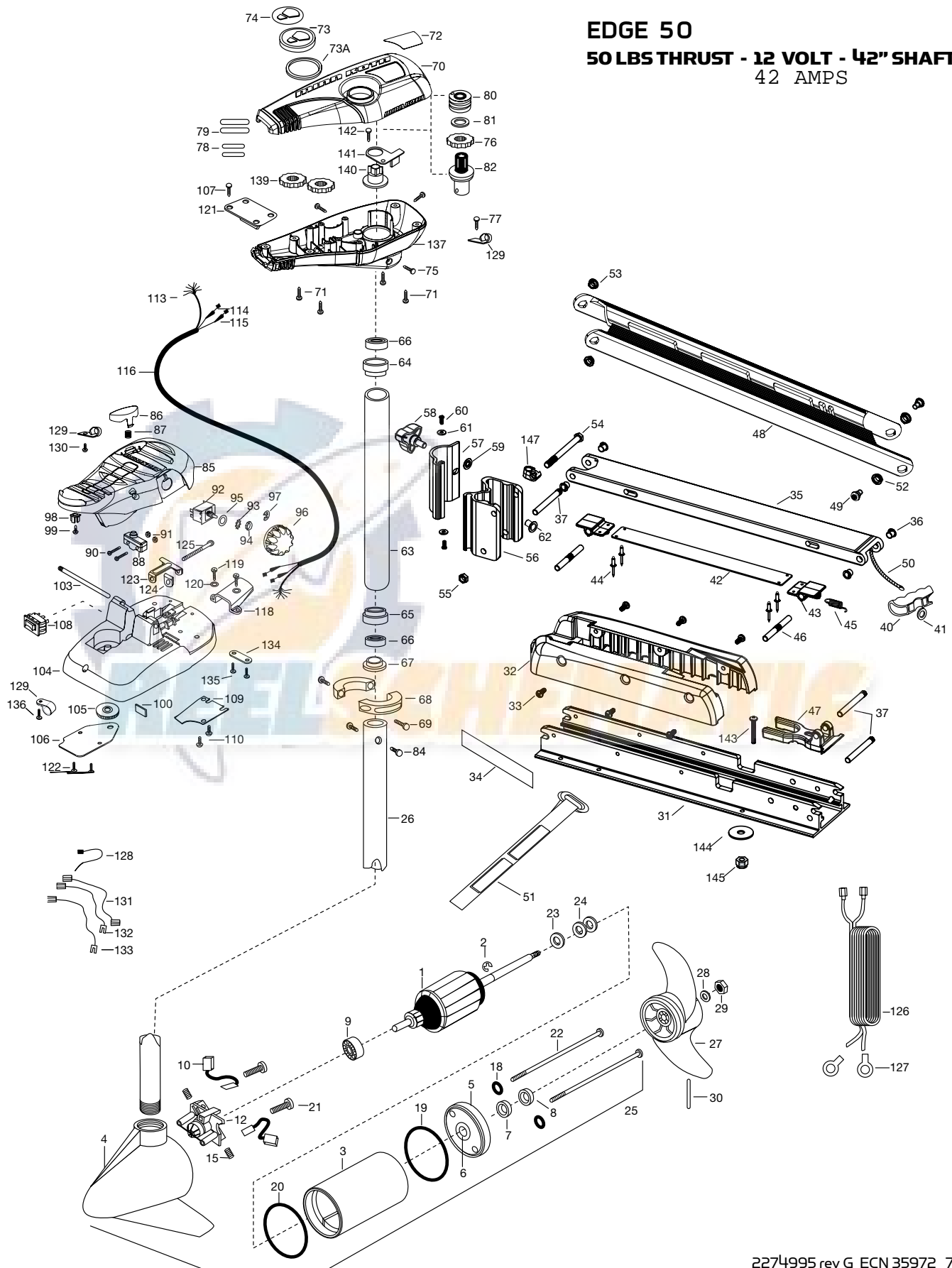

## EDGE 50

## 50 LBS THRUST - 12 VOLT - 42" SHAFT

ITEM	QTY	PART NUMBER	DESCRIPTION	ITEM	QTY	PART NUMBER	DESCRIPTION	ITEM	QTY	PART NUMBER	DESCRIPTION
1	1	2-100-117	ARM ASSEMBLY 12 V 3.625	59	1	2261728	RETAINING WASHER- 3/8"	114	1	2267505	RIGHT CABLE ASSEMBLY 5'
2	1	788-015	RETAINING RING	60	2	2053415	SCREW #8-32 X 3/8" TRI	115	1	2267515	LEFT CABLE ASSEMBLY 5'
3	1	2-200-101	HOUSING ASSEMBLY CENTER TXT	61	2	2261732	WASHER #8, NYLON	116	1	2265430	CABLE JACKET 5'
4	1	2-300-195	HOUSING -ASSEMBLY BRUSH END	62	2	2264703	THREADED INSERT	118	1	2265115	BOOT-FOOT PEDAL BASE
5	1	2-400-101	PLAIN END HOUSING ASSEMBLY		1	2992015	TUBE W/BEARING RACE ASSEMBLY 18"	119	2	2372100	SCREW – #8-18 X 5/8 THD
6	1	144-049	FLANGE BEARING [SERVICE ONLY]	63	1	2272066	18" TUBE OUTER 4 HOLES	120	2	2261714	FOOT PEDAL WASHER
7	1	880-003	SEAL	64	1	2266260	BEARING RACE	121	1	2261901	CONDUIT BRACKET
8	1	880-006	SEAL WITH SHIELD	65	1	2266220	STEEL BEARING RACE	122	2	2301310	SCREW – #8-18 X 3/4"
9	1	140-010	BALL BEARING	66	2	2266000	STEEL BEARING BALL	123	1	2263210	CONDUIT ADJUSTMENT BRACKET
10	2	188-036	BRUSH ASSEMBLY	67	1	2266115	BEARING CONE	124	1	2263140	NYLOCK KEEPER
12	1	738-036	BRUSH PLATE W/HOLDER 3.625	68	2	2261622	ALUMINUM HALF-COLLAR	125	1	2263466	SCREW – 1/4-20 X 2
15	2	975-040	TORSION SPRING	69	2	2263453	SCREW – 1/4X20 X 1"	126	1	2261235	LEADWIRE-BATTERY
18	2	701-008	O-RING	70	1	2260215	CONTROL BOX COVER	127	2	2020700	TERMINAL RING, 3/8"
19	1	701-081	O-RING MK406460	71	6	2372100	SCREW – 8-18 X 5/8 THD	128	1	2256300	BLACK TIE WRAP-5.5"
20	1	337-036	GASKET	72	1	2275612	DECAL-COVER, EDGE 50/FC	129	3	2263201	CLAMP WIRE HARNESS MICRO
21	2	830-007	SCREW – SELF-THREAD #8-32X1.7	73	1	2260153	POINTER DISC SHORT YELLOW	130	1	2332103	SCREW – #6-20 X 3/8 THD
22	2	830-042	THRU BOLT 8-32 X 8.96	73A	1	2261733	WASHER-FOAM, INDICATOR	131	1	2260301	CONNECTING WIRE SWITCH
23	1	990-067	STEEL THRUST WASHER	74	1	2265800	DECAL-INDICATOR	132	1	2260312	WIRE – BLK W/SHT- 19 1/2"
24	2	990-070	NYLATRON WASHER	75	3	2053414	SCREW-8-32 X 1/2 TRI LOBE	133	1	2260322	WIRE – BLK W/BLUE -12"
25	1	2097076	MTR ASSEMBLY 12V 3.625	76	1	2267800	GEAR-INDICATOR	134	1	2263205	LEADWIRE CLAMP
26	1	2032063	TUBE (COMP)W/CSK HOLE	77	1	2372100	SCREW-8-18 X 5/8 THD	135	2	9953104	SCREW – #8 X 1/2" SS
■	1	1378131	PROPELLER KIT	78	2	2375400	SHRINK TUBE-1/4OD X 1-3/4	136	1	2301310	SCREW – #8 -18 X 1/2" SS
27	1	2061160	PROPELLER	79	2	2355410	SHRINK TUBE-3/8 OD X 2	137	1	2262515	CONTROL BOX BOTTOM
28	1	2151726	WASHER- 5/16 SS	80	1	2232360	PULLEY – CABLE DRUM	139	2	2267800	INDICATOR GEAR
29	1	2053101	NUT-PROP NYLOC	81	1	2261730	NYLON A/T WASHER	140	1	2262221	YELLOW DRIVE INDICATOR
30	1	2092600	DRIVE PIN	82	1	2996246	BEARING RACE/ PINION ASSEMBLY	141	1	2269105	BRACKET/INDICATOR
31	1	2266502	BOWPLATE, FW, STD	84	2	2263410	SCREW – #8-32 X 5/16	142	1	2223430	SCREW – #8X 3/4 PPH TYPE 25 SS
32	1	2263905	BLACK MOTOR REST	85	1	2994496	FOOT PEDAL/PLUG ASSEMBLY	■	1	2994838	BAG ASSEMBLY
33	6	2303430	SCREW 1/4-20 X 5/8	86	1	2283700	PUSH-BUTTON	*143	6	2263462	SCREW 1/4-20X2 SS
34	2	2265667	MOTOR REST DECAL, FW	87	1	2302732	LOWER PEDAL SPRING	*144	6	2261713	WASHER – 1/4 FLAT 18-18
■	1	2991716	MOUNT, ASSY SHORT FW	88	1	2264040	MOMENTARY SWITCH	*145	6	2263103	1/4-20 NYLOCK-JAM NUT
35	1	2264372	LOWER ARM, FW, STD.	90	2	2262114	MOUNTING/SWITCH SCREW	147	1	2262310	GUIDE ROPE
36	4	2266002	NYLINER 3/8" SHAFT	91	2	2233100	SWITCH MOUNT NUT	■	1	2888460	SEAL & O-RING KIT
37	3	2260503	PIVOT PIN	92	1	2264026	SWITCH – 5 SPEED				
40	1	2150405	PULL-GRIP	93	1	2261701	LOCKWASHER-STAR				
41	1	2151700	WASHER-EYE SHAFT .562 OD	94	1	2263105	HEX NUT				
■	1	2993811	LATCH STRAP ASSY, STD	95	1	2261715	SPACER-SWITCH 5 SP MODELS				
42	1	2263605	LATCH STRAP, STD	96	1	2280110	SPEED CONTROL KNOB 5SPD				
43	2	2261903	LATCH BRACKET	97	1	2263000	E-RING TRU-ARC				
44	4	2268602	RIVET 1/8" SS	98	1	2260730	CONNECTOR 1/4 MALE TAB				
45	1	2262709	SPRING-LATCH PIN	99	1	2332103	SCREW – #6-20 X 3/8				
46	2	2260501	LATCH PIN	100	1	2266413	TENSION SCREW PLATE FOOT PEDAL				
47	1	2261544	YOKE-TUBE	103	1	2260511	PIN-PIVOT A/T FOOT PEDAL				
48	1	2264271	ARM-UPPER, SHORT FW	104	1	2992104	FOOT PEDAL BASE/PIN ASSEMBLY SONAR				
49	2	2263510	BOLT-SHOULDER, SS	105	1	2262301	PULLEY-FOOT PEDAL				
50	1	2251601	ROPE- 44.5"	106	1	2266401	COVER-PULLEY STAMPING				
51	1	2263805	VELCRO STRAP	107	4	2223430	SCREW-#8X 3/4				
52	1	2267302	BUSHING –LOWER 7/16" ID, SS	108	1	2254031	MOM/OFF/COM SWITCH				
53	1	2267303	BUSING – UPPER 3/8" ID, SS	109	1	2265412	FOOT PEDAL SWITCH PLATE				
54	1	2263505	BOLT 3/8-16 X 4.25"	110	2	2332103	SCREW – #6-20 X 3/8 THD				
55	1	2263114	NYLOCK JAM NUT 3/8-16	113	1	2261208	WIRE HARNESS, A/T FOOT PEDAL				
56	1	2261892	HINGE BASE, FW								
57	1	2261897	HINGE DOOR, FW								
58	1	2260905	SOFT GRIP HANDLE, L&D								

■ THIS ITEM IS PART OF AN ASSEMBLY.

\*THIS ITEM IS PART OF A KIT AND ONLY LISTED FOR VIEWING PURPOSES.

# MOTOR WIRING DIAGRAM

**NOTE:** This is a universal, multi-voltage diagram. Double-check your motor's voltage for proper connections. Over-Current Protection Devices not shown in this illustration. Edge 50 is 12-volt only!

